

Babylon Yacht Club
July 4th Invitational Regatta
PATROL BOAT 102



Equipment:

- VHF (channel 13/72) (most race communication will be on 72)
- Rope for towing/securing/righting participating vessels
- Anchor w/ line
- Cooler / Non-alcoholic refreshments
- Sun lotion
- Throw-able PFD

Patrol boats are generally assigned to a Race Committee, (RC). Before heading out, check in with the Regatta Chair for your assignment. When you know your assignment, go out to that RC and ask them where they want you to patrol.

There will be a lot of radio chatter and most hails will be preceded with the word '*Division*' as in "Division 1 mark-set, this is Division 1 Committee come in". It helps clarify so please use it. If you're being instructed in 'sail talk' with words like "Gybe mark" or "leeward mark", feel free to ask them to repeat in English. Don't be embarrassed. See the chart on the flip side for a better understanding.

Patrol boat duty is typically uneventful until a boat goes over and all hell breaks out. That's when the Patrol boat becomes the most important boat in the Regatta. Safety is your primary responsibility. It is important to avoid unsolicited contact with a participant since a boat may be disqualified for receiving outside help. If a sailor is in trouble approach the boat and ask him/her if they would like assistance. If they answer in the negative, station yourself nearby until they recover. If they request help, render assistance as necessary. Call in backup if you need. There are other boats out there that can help. Remember, safety is paramount and you are the adult. If there is a serious situation unfolding and you feel it is necessary to intercede without an explicit request --- state your intention and take the action necessary. The Regatta Committee will handle any repercussions.

Every patrol boat should have at least two people on board, one to operate the boat and another to handle lines. If you need a shore side break, coordinate with either the Race Committee or contact the "Regatta Chair" via VHF. It is important to ensure safety coverage is not comprised. Some classes/divisions return to the club house for lunch and some do not. Lunch will be brought out for those classes that like to race through lunch. The patrol crews will also be getting a lunch- exactly when/where will be worked out on race day.

The USCG requested that all patrol boats be informed of the following:

As the event sponsor, you are responsible for ensuring the safety of the participants in your event and ensuring that the safety vessels understand that they shall comply with the Navigation Rules of the Road. They do not automatically become "Stand On" (privileged) vessels by virtue of their participation in the event, particularly regarding the rules governing meeting, crossing, and overtaking situations between participants and vessels restricted in their ability to maneuver.

The east dock is reserved for patrol boats and the Commodore's room is open for Regatta volunteers only. There will be food and snacks available. Also, after your daily patrol is done, feel free to help yourself to the adult refreshments available. Enjoy your day and thank you for volunteering for this assignment.

Regatta Chair (Marty) 516 --- ---- (cell)
631 --- ---- (alternate cell)

The race course generally has a triangular layout to test a sailors' abilities at all points of wind. The layout is **always** set in relation to the wind

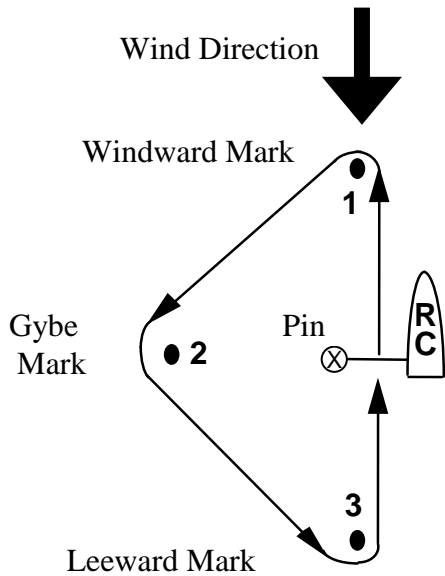

The starting sequence shown below is the three-minute dinghy start. Ten short blasts go off twenty seconds before the three-minute gun.

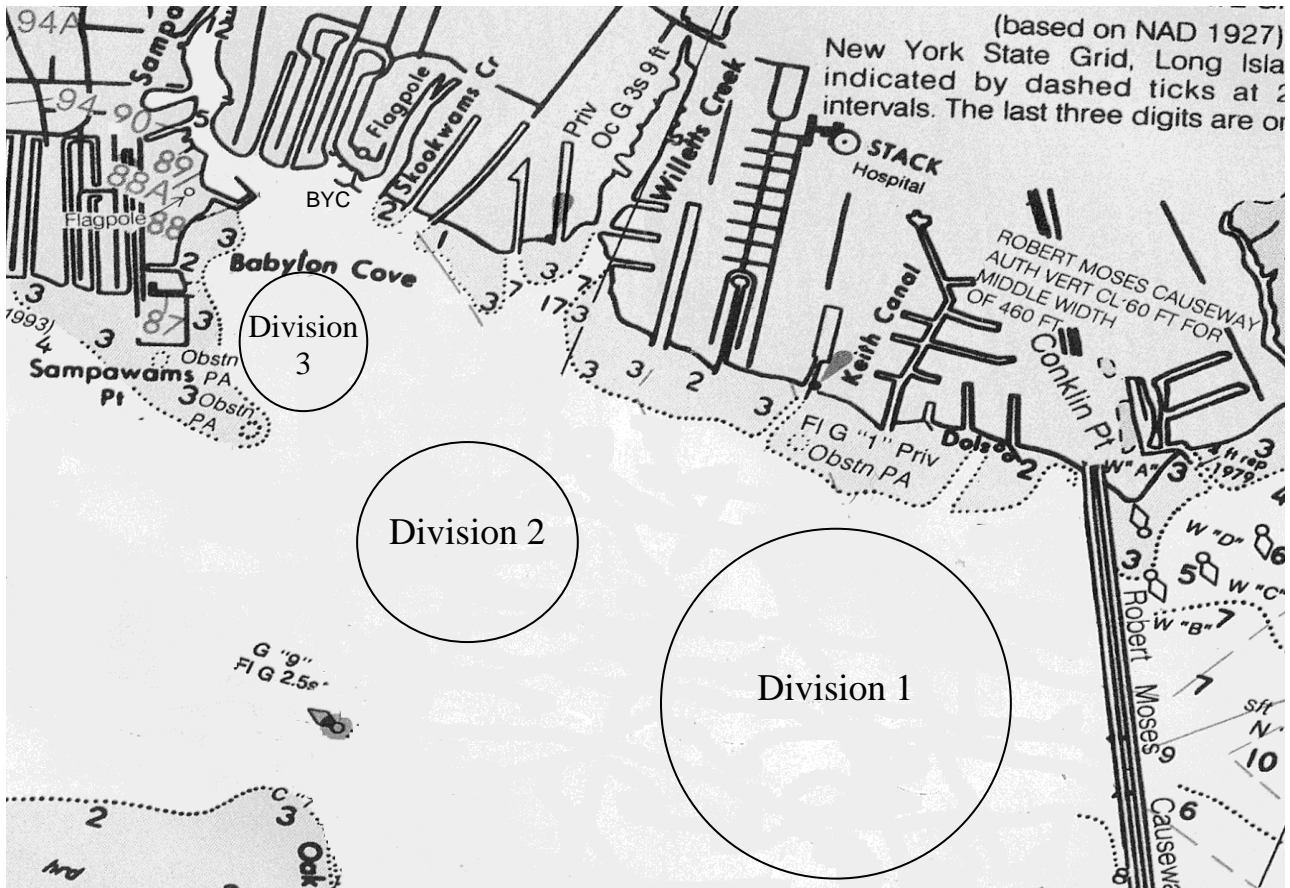
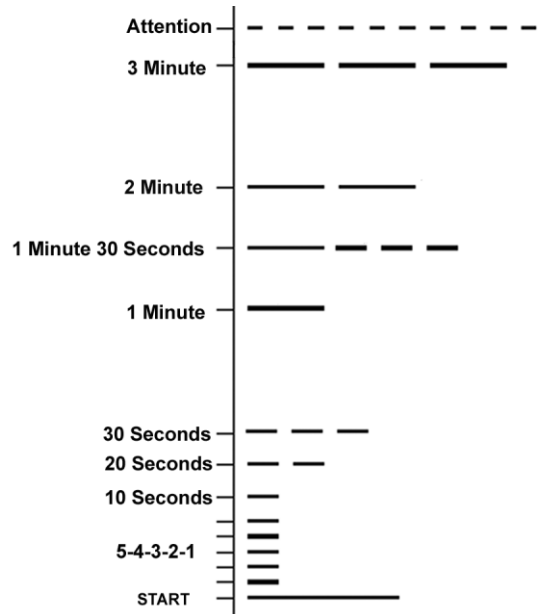

Not to scale